

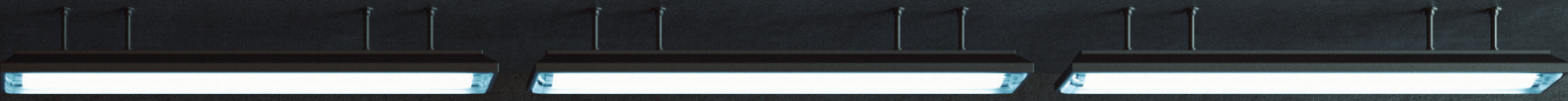

MERLIN

CPS system



MERLIN CPS – The system

In the event of a mains failure, the MERLIN CPS system supplies the connected exit sign and emergency luminaires via a battery system.

All final circuits are pre-equipped for mixed technology (escape route and emergency luminaires in one circuit) and can be loaded up to max. 650 VA. Communication with the luminaires takes place on the supply line (without additional BUS cable). Each address can be assigned a clear, unique location text to enable a luminaire to be localised quickly and conveniently in case of a fault.

The monitoring of the general lighting can be ensured by means of MERLIN BUS mains monitors.

In the event of a failure, the emergency lighting for the area concerned is switched on automatically. Each BUS mains monitor can be assigned a unique location test, so that the local normal supply fault can be corrected in a targeted way.

Another advantage is that only one supply cable from the central unit is required to supply MERLIN substations. This reduces the wiring required and the fire load by 50%.

The universal MERLIN charging unit allows all standard battery types as the standby electricity source, such as OGI battery (sealed lead grid plates), OPsV battery (sealed lead heavy-duty plates) and OPzS battery (closed lead heavy duty plates).

Whether BACnet or Modbus interface. MERLIN transfers the data in the required format.

Voltage-free signalling contacts are naturally included as a standard feature.

You want visualisation of the system and all connected luminaires. Not a problem.

You can access the complete system via a TCP/IP interface. We would be pleased to help you to program your MERLIN CPS system by means of remote access.

The MERLIN CPS system is produced in accordance with the respective current standard (EN 50171).

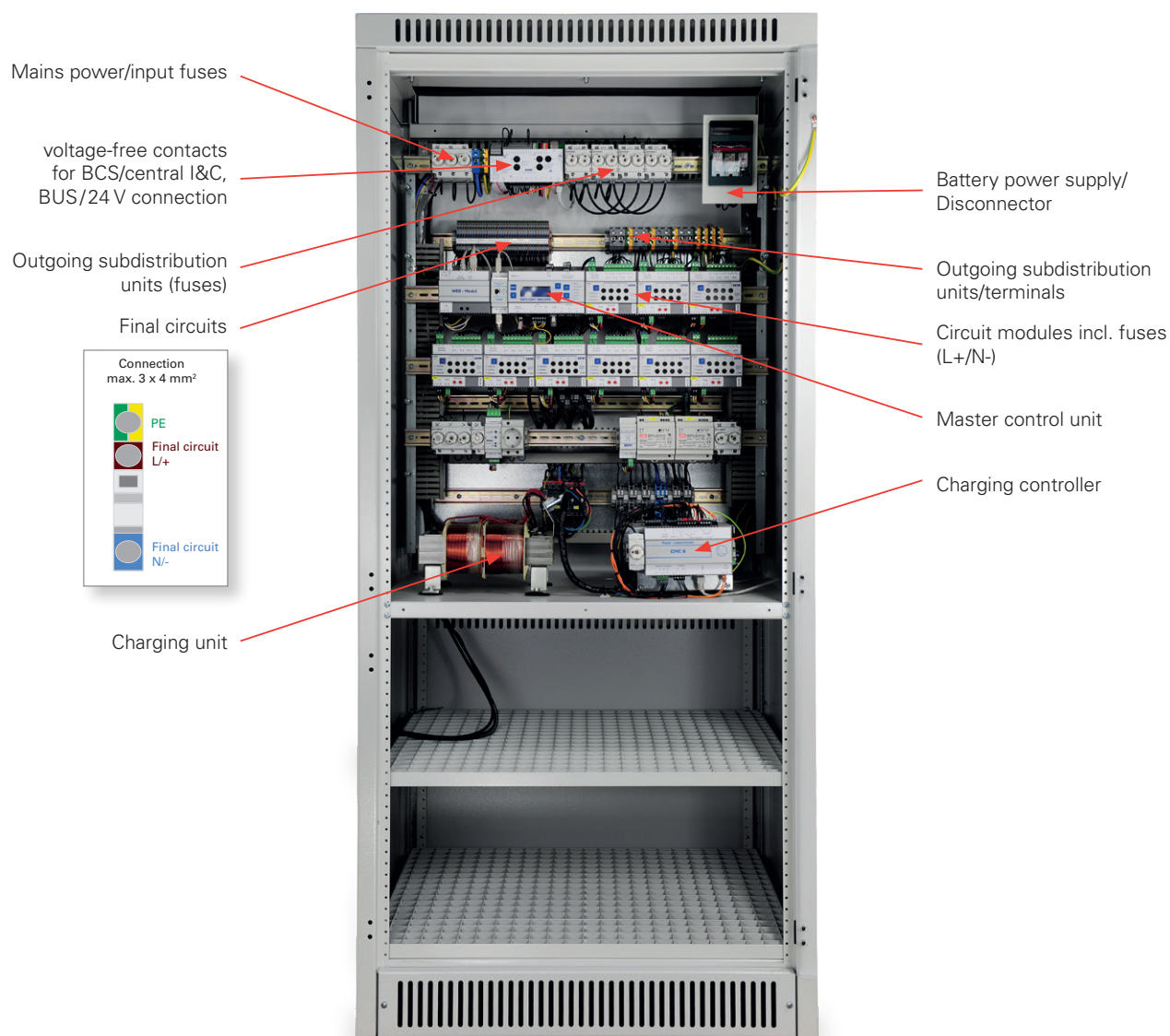

TECHNICAL DATA

- Max. power: 150 kVA, Output voltage: 230 V AC/DC
- Standard single luminaire monitoring using address modules
- Freely programmable final circuits for maintained and non-maintained light and mixed technology
- Microprocessor-controlled functional and duration test
- Programming optionally via PC
- Ethernet connection for web browser visualisation
- Autom. test equipment with logging/recording of results
- Optional: Higher-level visualisation via WEB-MASTER
- Optional: External IOM module (switch interrogation modules)

MERLIN CPS

SYSTEM DESCRIPTION

CPS systems use a battery system as a standby electricity source for safety purposes, to supply the connected loads in emergency mode. The bridging (stored energy time) is designed for 1h, 3h or 8h, depending on the requirements.

How it works

If a mains voltage is applied the loads are supplied from the mains and the battery system is charged. By monitoring the general lighting, it is ensured that in the event of a failure, the emergency lighting is switched on for the area concerned. In the event of failure or a fall in the mains voltage by more than 15%, the system switches to battery mode (DC mode). As a result, all connected exit sign and emergency luminaires, which are supplied from the central unit and the substations, are switched on automatically.

When the mains returns, the complete CPS system switches back to normal mode and charges the previously discharged battery system.

The luminaire test required by the standards is performed by MERLIN automatically and it records the result in the standard, integrated test log of the control unit.

REFERENCE: Tanzende Türme – Hamburg



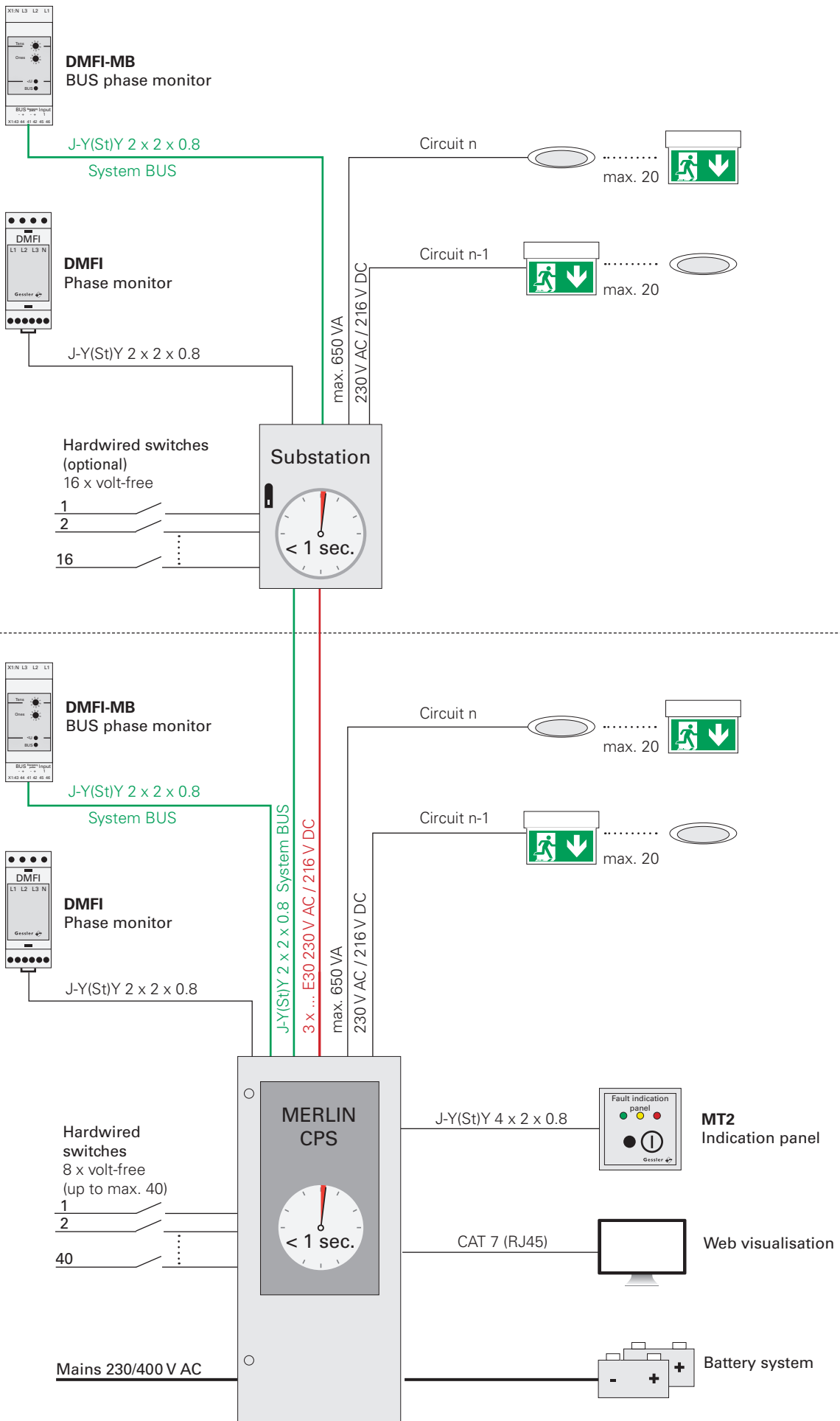

MERLINMaster



CONTROL UNIT

The master forms the heart of the system. It carries out all monitoring, logging and tests required by VDE 0108, EN 50172 and EN 50171.

The complete system can be programmed via the illuminated display.

All messages are displayed in plain text. The location texts can be input via the menu control or via a PC.

Examples:

Luminaire error, staircase 1, 2nd floor
Mains failure DMFI-BAV-UV Corridor 3, 2nd floor

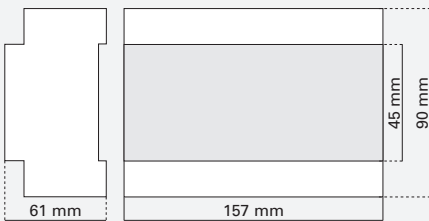

Top-hat rail mounting 9 HP

TECHNICAL DATA

MERLIN MASTER

Enclosure material	Plastic
Degree of protection	IP20
Display	4 x 20 characters
Operation / programming	via menu buttons
Hardwired switches	8 (freely programmable)
Connection ports	3 x RJ11 or 1 x USB 2 x RJ11

Substations can be optionally extended with a master. Due to the resulting distributed intelligence, all options are open to the owner/operator.



MERLIN-Button

Fast access to frequently used functions.

This button enables the owner/operator to call up a menu that they have compiled themselves with the press of a button.

8 x voltage-free hardwired switches
(freely programmable)

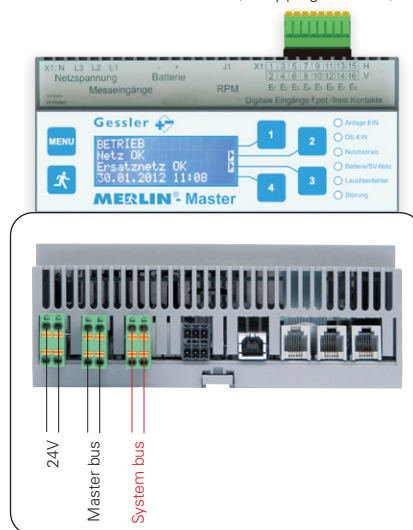

WEB BROWSER Visualisation

FUNCTIONAL DESCRIPTION

Access via a standard web browser enables user-friendly and self-explanatory menu navigation of the CPS system. All error messages and system data can be called up securely over the internet/intranet.

These are, g.g.:

- Visual display of all system information
- Continuous compilation and saving of the test log
- Display and printout and export of the test log
- Fault indication with detailed fault information
- Remote control of the system (ON/OFF, maintained luminaires ON/OFF, test initiation, circuit calibration)

DISPLAYS



Start page, system overview



Test results



Test log



Master remote control

BUS CABLE LENGTHS MERLIN

Max. total BUS length: 1,000 m
Max. distance from BUS device to the CPS system: 400 m

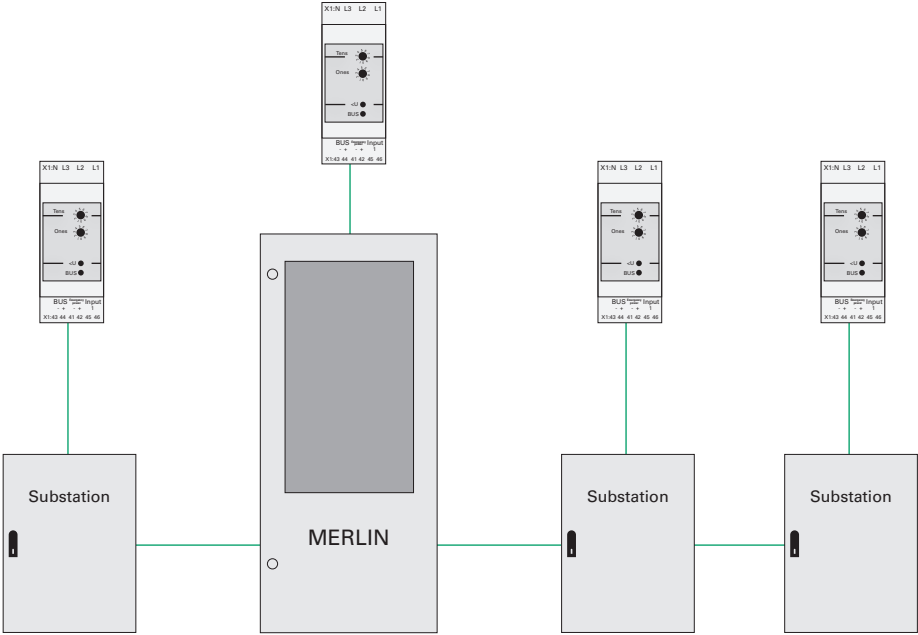
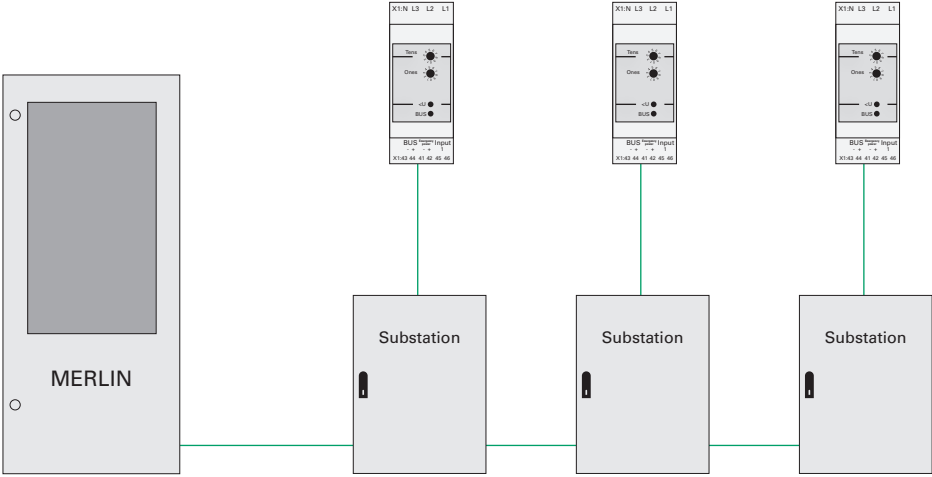

RISER JUNCTION BOX in E30

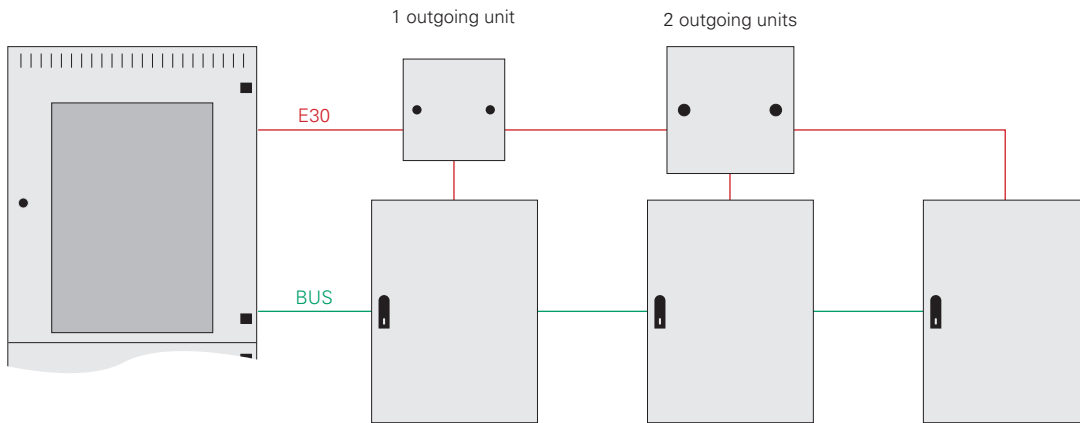
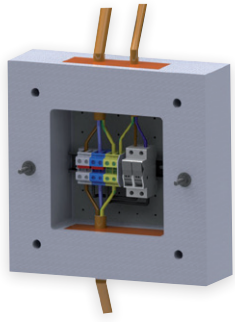

INDICATION PANEL MT2

CONNECTION PLAN FOR MERLIN

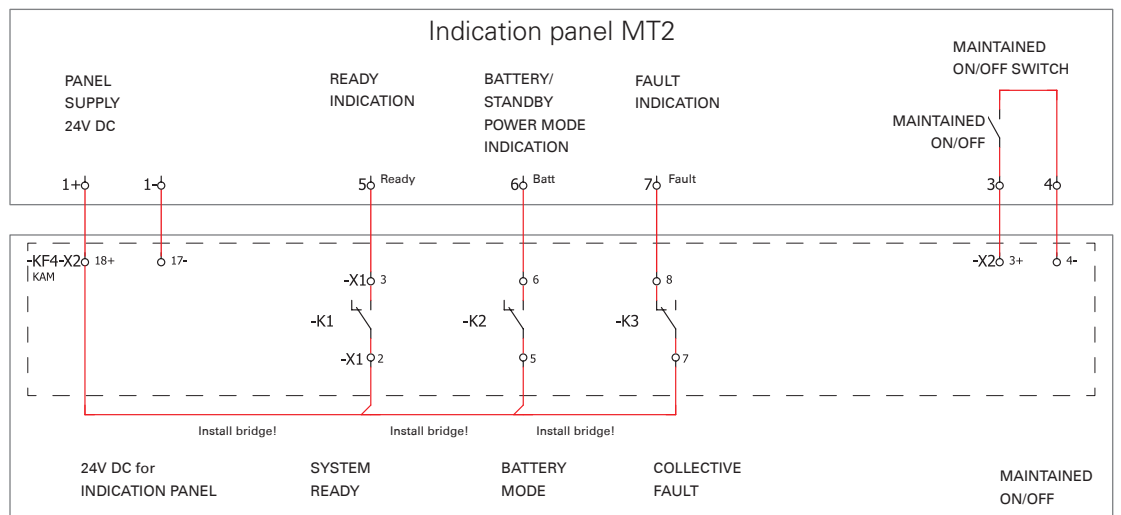
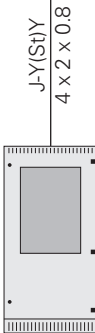

DMFI-MB

BUS phase monitor for MERLIN systems for monitoring the normal mains supply

DMFI-MB is a BUS phase monitor, which is used to monitor the normal mains supply.

Each DMFI-MB is connected to a Gessler LPS/CPS system via a BUS cable. A unique BUS address is assigned to each DMFI-MB by means of a rotary coder. A location text can be assigned at any time (to enable accurately targeted correction of a local fault in the normal mains supply).

As soon as one of the normal mains supply phases to be monitored falls below the nominal voltage by more than 15 %, the BUS phase monitor signals a local mains failure. The LPS/CPS system now switches on the emergency lighting off the area concerned and supplies the luminaires via the mains.



BUS MAINS MONITOR	DMFI-MB
Enclosure material	Plastic
Nominal voltage	230V ± 10 %, 50/60 Hz / 176-275 V DC
Power consumption	2 W
Backup fuse	max. 16 A
Address range	1 to 99
Hardwired switches	1 x 24 V via external voltage-free contacts
Display	LED status display
Class	I
System	MERLIN + Quattro

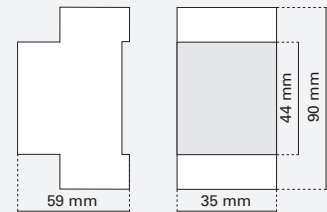

Top-hat rail mounting 2 HP

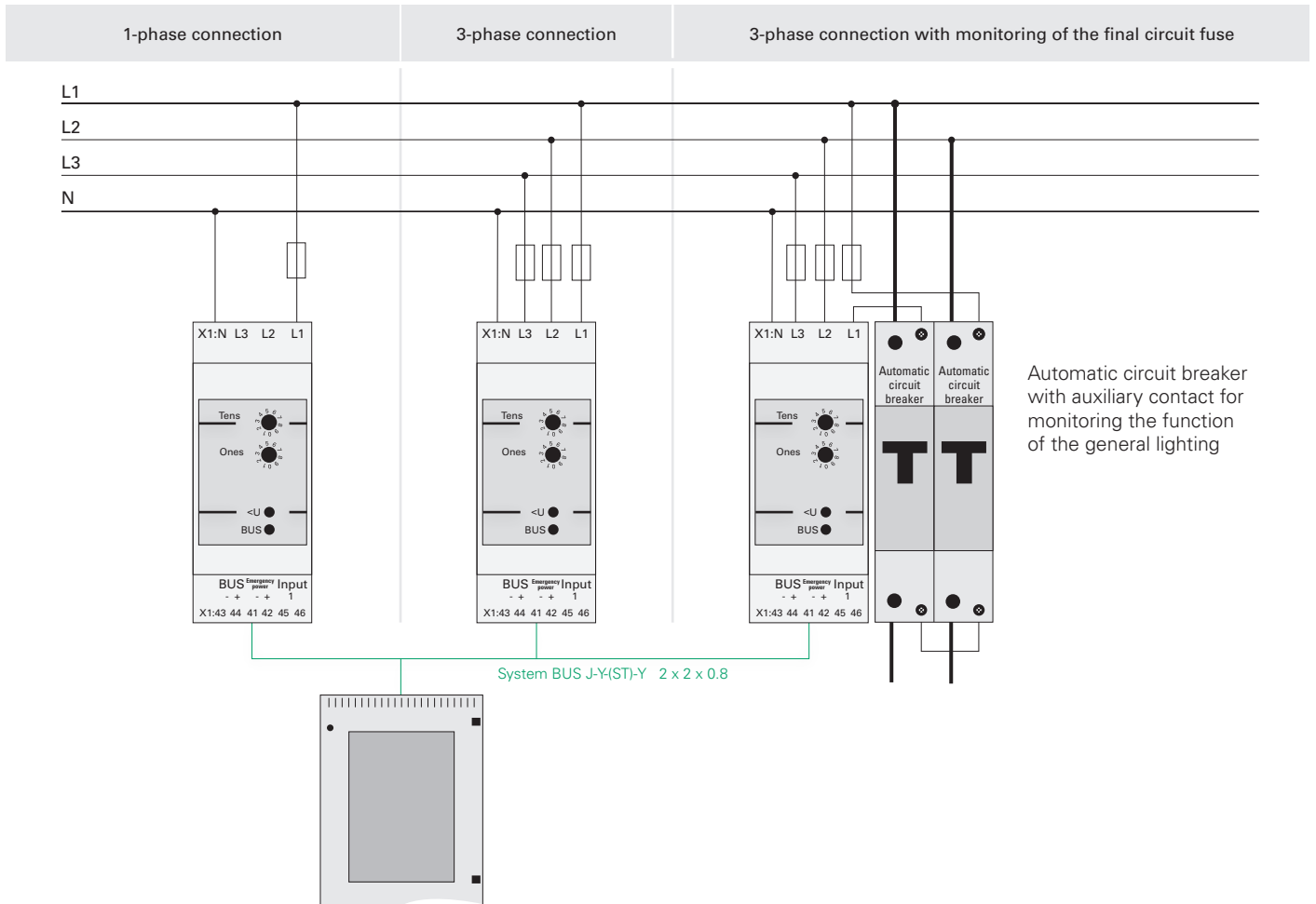

Automatic circuit breaker with auxiliary contact for monitoring the function of the general lighting

ASSEMBLIES | MODULES MERLIN

The following assemblies and modules are compatible with MERLIN:



MLB10

Address module for MERLIN systems

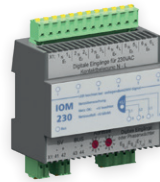

IOM230

Switch interrogation module 230 V for MERLIN systems



MLB10DD

Address module with DALI disconnection for MERLIN systems



IOM24

Switch interrogation module 24 V for MERLIN systems



DMFI-MB

BUS phase monitor for MERLIN systems



WEB-MASTER

High-level visualisation



DMFI

Phase monitor



MT2

Indication panel

DIMENSIONS

MERLIN main devices and substations

MAIN DEVICES

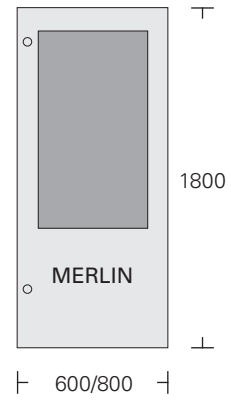
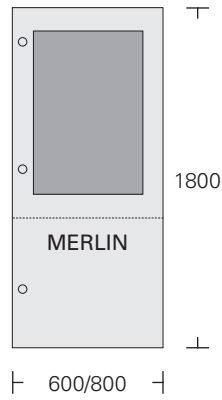
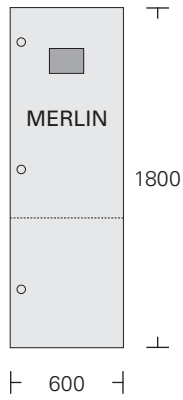

TECHNICAL DATA – SLIMLINE COMBINED CABINET

Dimensions H x W x D [mm]	max. outgoing units (2-pole)
1800 x 600 x 500	20
max. 9200 VA	

TECHNICAL DATA – COMBINED CABINET

Dimensions H x W x D [mm]	max. outgoing units (2-pole)
1800 x 600 x 450/600	20
1800 x 800 x 450/600	36
max. 9200 VA	

TECHNICAL DATA – EQUIPMENT CABINET

Dimensions H x W x D [mm]	max. outgoing units (2-pole)
1800 x 600 x 450/600	60
1800 x 800 x 450/600	72
max. 18000 VA	

BATTERY CABINET

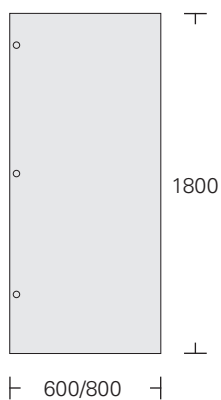

TECHNICAL DATA – BATTERY CABINET

Dimensions H x W x D [mm]
1800 x 600 x 600
1800 x 800 x 600

SHEET STEEL SUBSTATIONS (E0)

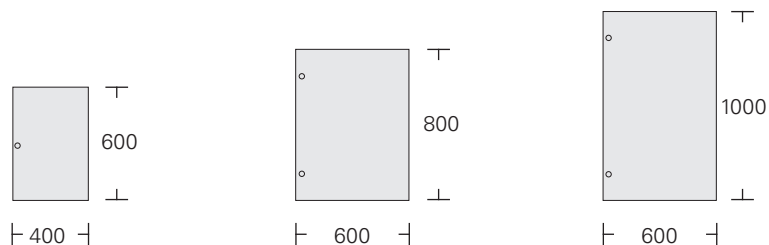

PVC SUBSTATION (E0)

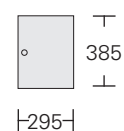

TECHNICAL DATA – SUBSTATIONS in E0

Dimensions H x W x D [mm]	max. outgoing units (2-pole)	Version
600 x 400 x 250	12	Wall-mounted cabinet
800 x 600 x 250	32	Wall-mounted cabinet
1000 x 600 x 250	44	Wall-mounted cabinet
Colour: RAL 7035		
Degree of protection: IP20		

TECHNICAL DATA – SUBSTATION in E0

Dimensions H x W x D [mm]	max. outgoing units (2-pole)
385 x 295 x 110	8
Colour: RAL 9010	
Degree of protection: IP43	
Version	
Wall-mounted cabinet	

SUBSTATIONS IN MAINTENANCE OF INTEGRITY (E30)

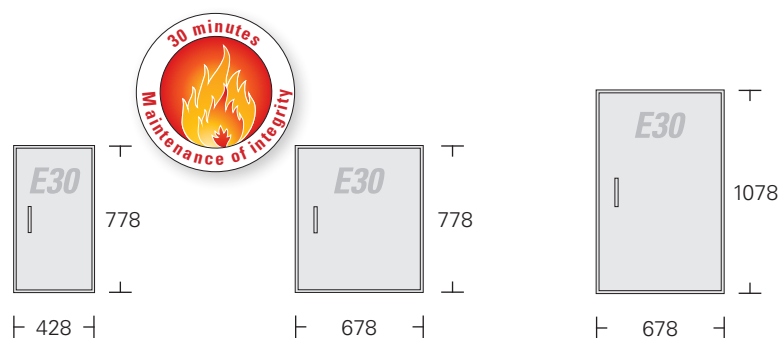

TECHNICAL DATA – SUBSTATIONS in MAINTENANCE OF INTEGRITY

Dimensions H x W x D [mm]	max. outgoing units (2-pole)	Version
778 x 428 x 275	8	Wall-mounted cabinet
778 x 678 x 325	28	Wall-mounted cabinet
1078 x 678 x 325	52	Wall-mounted cabinet
Colour: RAL 7035		
Degree of protection: IP54		



MERLIN KV 2000

LPS system

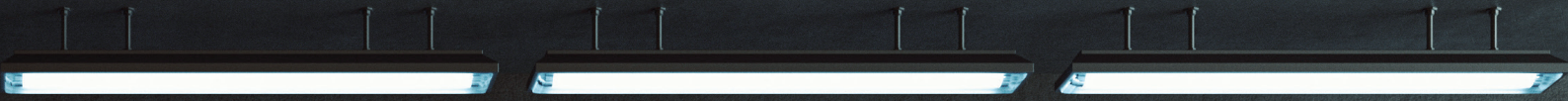

MERLIN KV2000 – The System

In the event of a mains failure, the MERLIN KV2000 LPS system supplies the connected luminaires via a battery system. All final circuits are pre-equipped for mixed technology (escape route and emergency luminaires in one circuit) and can be loaded up to max. 650 VA. The power of LPS systems is limited by the standards. Nonetheless, with 2000 W for 1h, 800 W for 3h and 370 W for 8h, the MERLIN KV2000 is a compact power wizard.

Communication with the luminaires takes place on the supply line (without additional BUS cable). Each address can be assigned a clear, unique location text to enable a luminaire to be localised quickly and conveniently in case of a fault.

The monitoring of the general lighting can be ensured by means of MERLIN BUS phase monitors. In the event of a failure, the emergency lighting for the area concerned is switched on automatically. Each BUS phase monitor can be assigned a unique location test, so that the local normal supply fault can be corrected in a targeted way.

Whether BACnet or Modbus interface, MERLIN transfers the data in the required format. Voltage-free signalling contacts are naturally included as a standard feature.

You want visualisation of the system and all connected luminaires. Not a problem.

You can access the complete system via a TCP/IP interface. We would be pleased to help you to program your MERLIN LPS system by means of remote access.

MERLIN KV2000 is produced in accordance with the respective current standard (EN 50171).

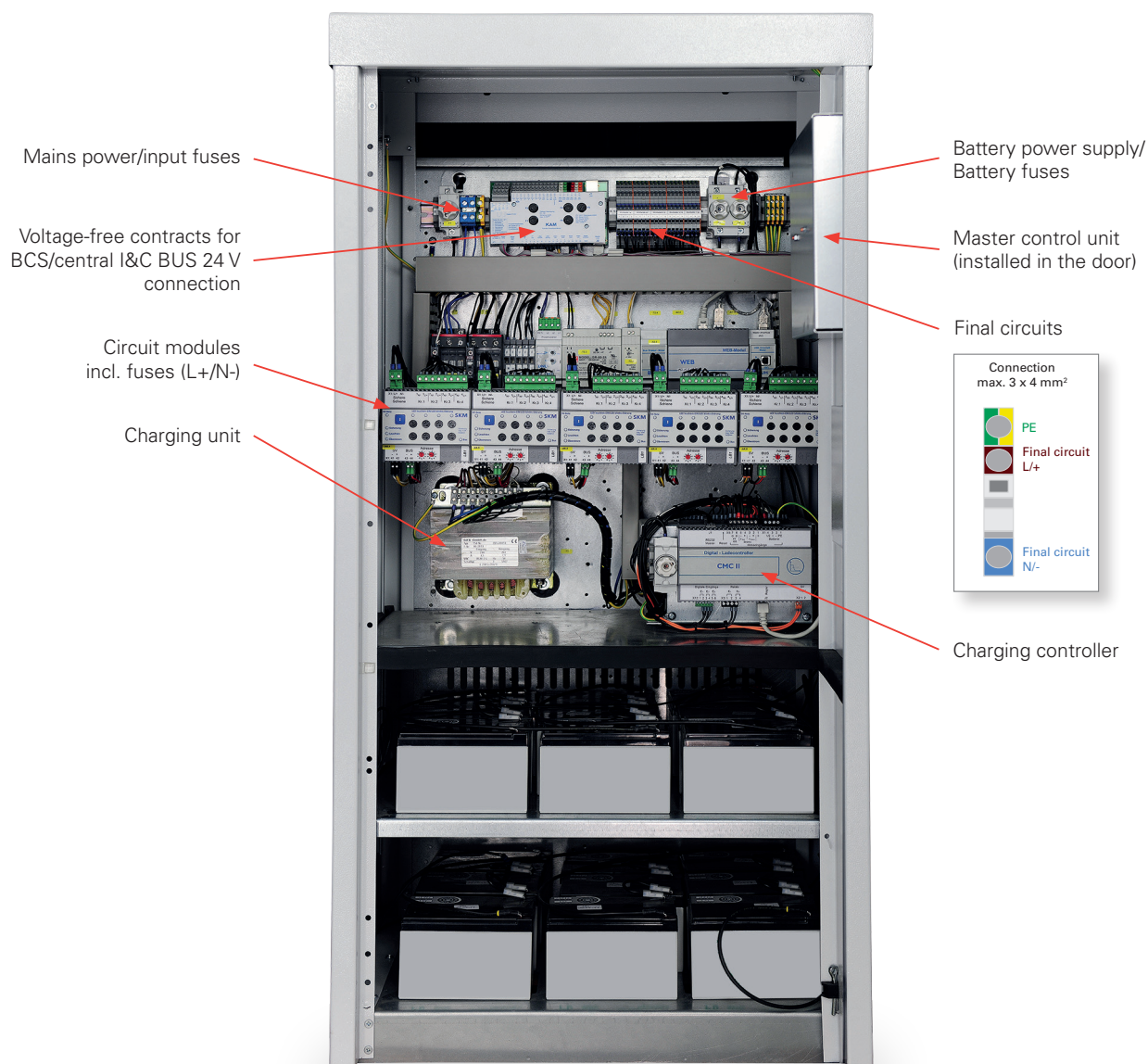

TECHNICAL DATA

- Power 1h: 2000 W
3h power: 800 W
8h power: 370 W
incl. 25 % ageing reserve
- 4, 8, 12, 16 or 20 circuits (5A each)
230V output voltage AC/DC
- Standard single luminaire monitoring using address modules
- Freely programmable final circuits for maintained and non-maintained light and mixed technology
- Microprocessor-controlled functional and duration test
- Programming optionally via PC
- Ethernet connection for web browser visualisation
- Autom. test equipment with logging/recording of results
- Optional: Higher-level visualisation via WEB-MASTER
- Optional: External IOM modules (switch interrogation modules)
- Optional: Installed in tested E-30 fire protection cabinet

MERLIN KV2000

SYSTEM DESCRIPTION

LPS systems use a battery system as a standby electricity source, to supply the connected loads in emergency mode. The bridging (stored energy time) is designed for 1h, 3h or 8h, depending on the requirements.

How it works

If a mains voltage is applied the loads are supplied from the mains and the battery system is charged. By monitoring the general lighting, it is ensured that in the event of a failure, the emergency lighting is switched on for the area concerned. In the event of failure or a fall in the mains voltage by more than 15%, the system switches to battery mode (DC mode). As a result, the connected escape route and emergency luminaires are switched on automatically.

As soon as a returning mains voltage is detected, MERLIN KV2000 switches to normal mode and again charges the battery system.

The luminaire test required by the standards is performed by the LPS system automatically and it records the result in the standard, integrated test log of the control unit.

REFERENCE: LOOP5 shopping centre – Weiterstadt



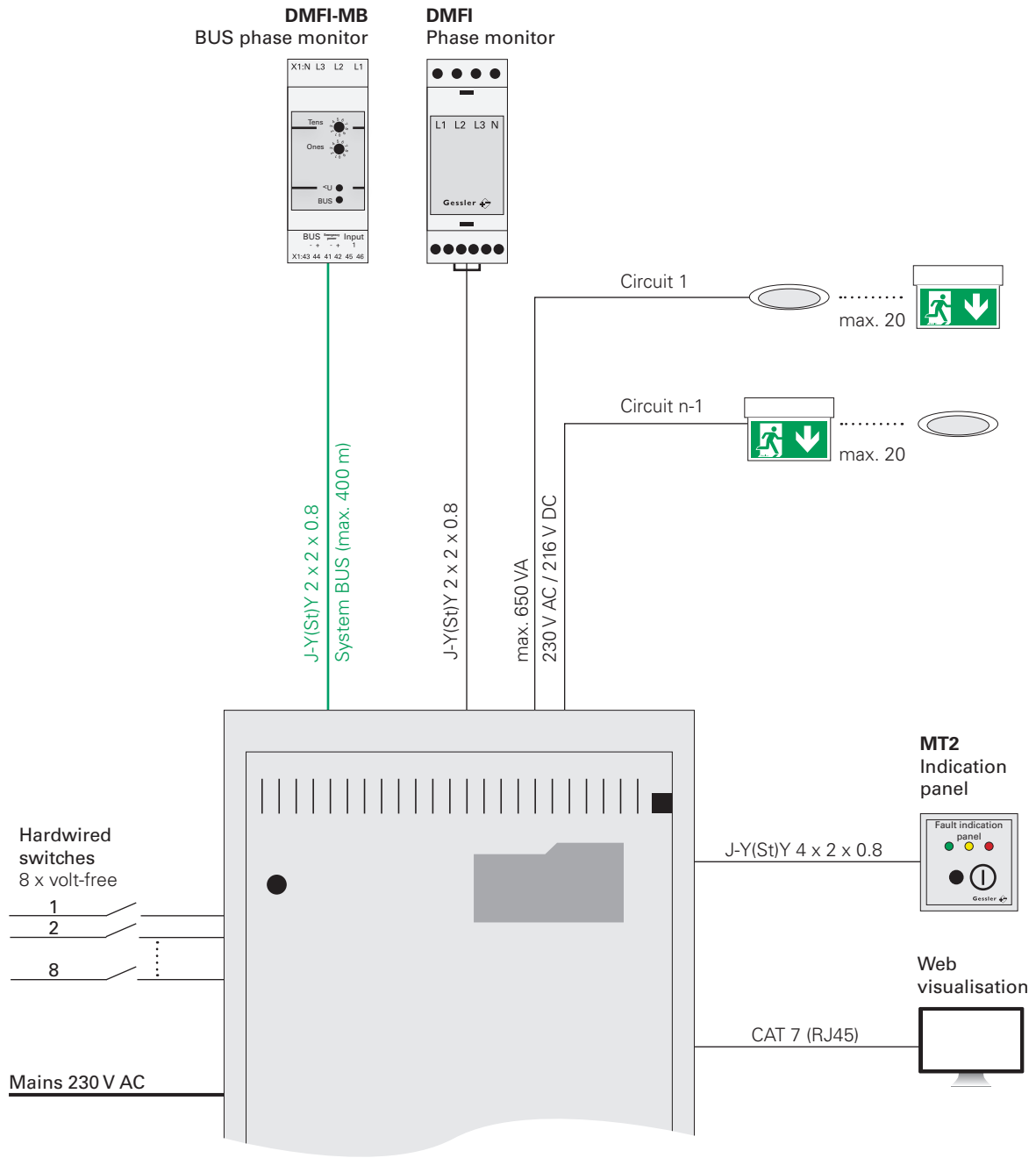

MT2

CONNECTION PLAN FOR KV2000

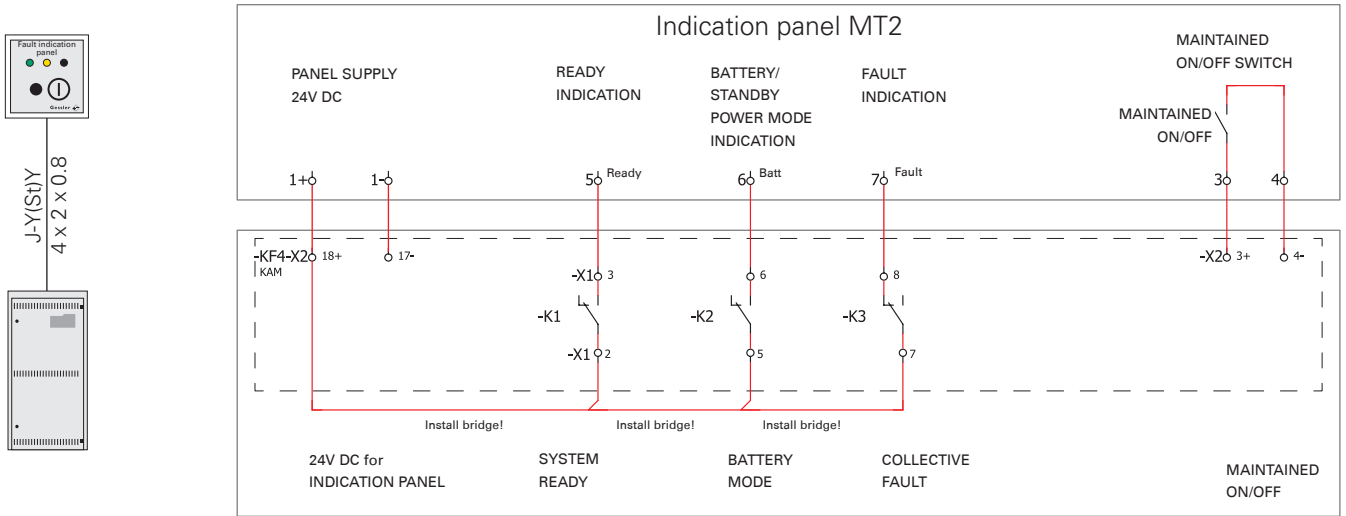

DIMENSIONS

MERLIN KV2000

MERLIN KV2000

MERLIN IN MAINTENANCE OF INTEGRITY (E30)

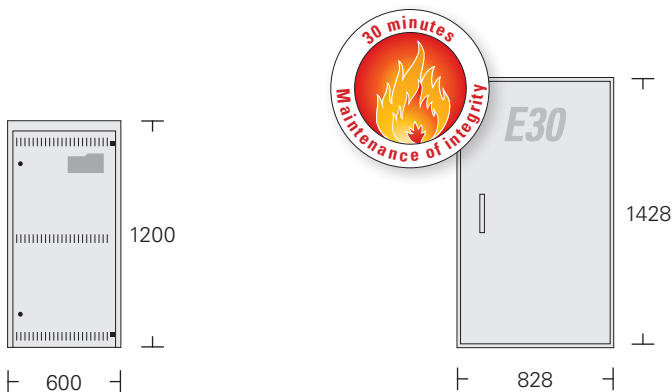

TECHNICAL DATA – MERLIN KV2000

Dimensions H x W x D [mm]

1200 x 600 x 430

Weight incl. batteries: approx. 150 kg

TECHNICAL DATA – MERLIN KV2000 in E30

Dimensions H x W x D [mm]

1428 x 828 x 575

Weight incl. device approx. 350 kg

ASSEMBLIES | MODULES KV2000

The following assemblies and modules are compatible with MERLIN:



MLB10
Address module for MERLIN systems

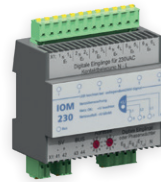

IOM230
Switch interrogation module 230 V for MERLIN systems



MLB10DD
Address module with DALI disconnection for MERLIN systems



IOM24
Switch interrogation module 24 V for MERLIN systems



DMFI-MB
BUS phase monitor for MERLIN systems



WEB-MASTER
High-level visualisation



DMFI
Phase monitor



MT2
Indication panel

The image shows three rectangular emergency light fixtures mounted on a dark, textured wall. The fixtures are illuminated, casting a bright white light. The background wall is dark and has a mottled, industrial appearance. A semi-transparent white rectangular box is overlaid on the wall, containing the product name and description.

MERLIN QUATTRO LIGHT

Emergency lighting system

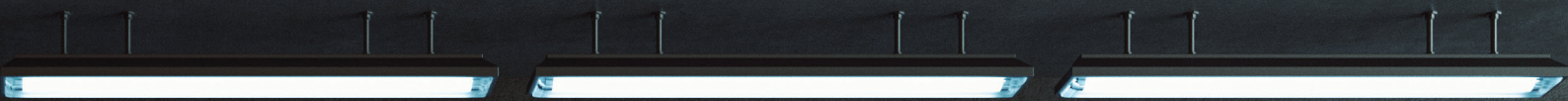

MERLIN QUATTRO LIGHT

The System

MERLIN QUATTRO LIGHT is a new generation LPS system. Designed to supply exit sign and emergency luminaires of individual fire compartments, in the event of a mains failure, QUATTRO LIGHT supplies all connected luminaires via a compact (low-gasification) 24V battery system.

Despite the 24V battery voltage, QUATTRO LIGHT has a system output voltage of 230V in normal and emergency mode.

Advantages: Gessler emergency lights do not necessarily have to provide the lighting of the escape routes.

You have the possibility of supplying part of the 230V general lighting (e.g. staircase lighting) in emergency mode.

To supply several fire compartments by means of one system, QUATTRO LIGHT is installed in a fire protection cabinet. This combination has a national technical approval (Z-86.2-76) issued by the Deutschen Institut für Bautechnik (DIBt).

All final circuits are pre-equipped for mixed technology (escape route and emergency luminaires in one circuit). Communication with the luminaires takes place on the supply line (without additional BUS cable).

Each address can be assigned a clear, unique location text to enable a luminaire to be localised quickly and conveniently in case of a fault.

The monitoring of the general lighting can be ensured by means of MERLIN BUS phase monitors.

In the event of a failure, the emergency lighting for the area concerned is switched on automatically. Each BUS phase monitor can be assigned a unique location test, so that the local normal supply fault can be corrected in a targeted way.

You want visualisation of the system and all connected luminaires? Not a problem.

You can access the complete system via a TCP/IP interface.

QUATTRO LIGHT is produced in accordance with the respective current standard (EN 50171).

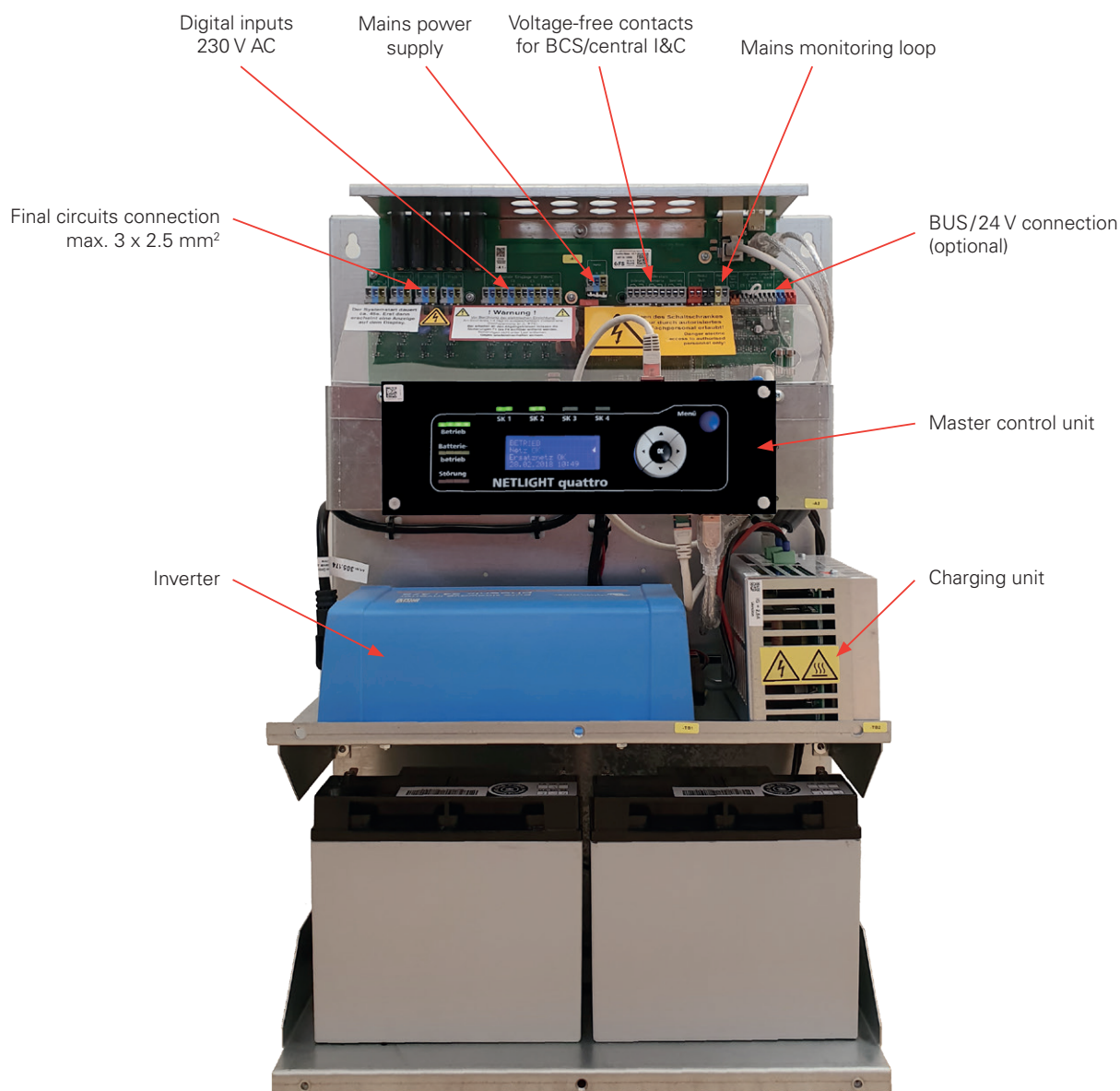

TECHNICAL DATA

- Power 1h: 250 VA / 350 VA
3h power: 225 VA / 350 VA
8h power: 88 VA / 188 VA / 250 VA
incl. 25 % ageing reserve
- 4 freely programmable final circuits (1.6 A each) for all operating modes
- 230 V output voltage (AC)
24 V battery voltage (DC)
- Standard single luminaire monitoring using address modules
- Freely programmable final circuits for maintained and non-maintained lighting and mixed technology
- Microprocessor-controlled functional and duration test
- Programming optionally via PC
- Ethernet connection for web browser visualisation
- Automatic test equipment with logging
- Optional: Higher-level visualisation via WEB-MASTER
- Optional: Installed in tested E-30 fire protection cabinet

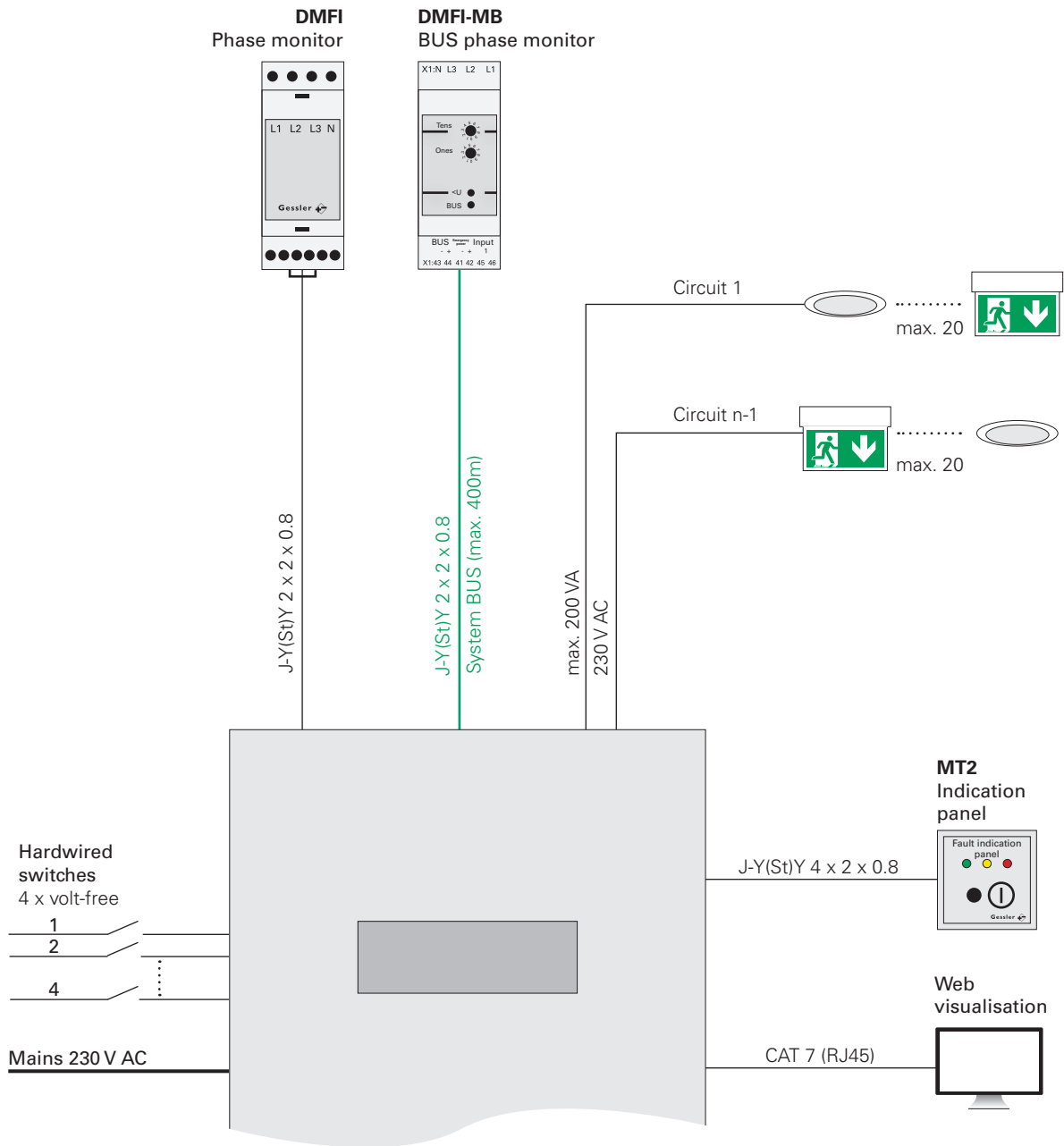

MT2

CONNECTION PLAN FOR MERLIN QUATTRO LIGHT

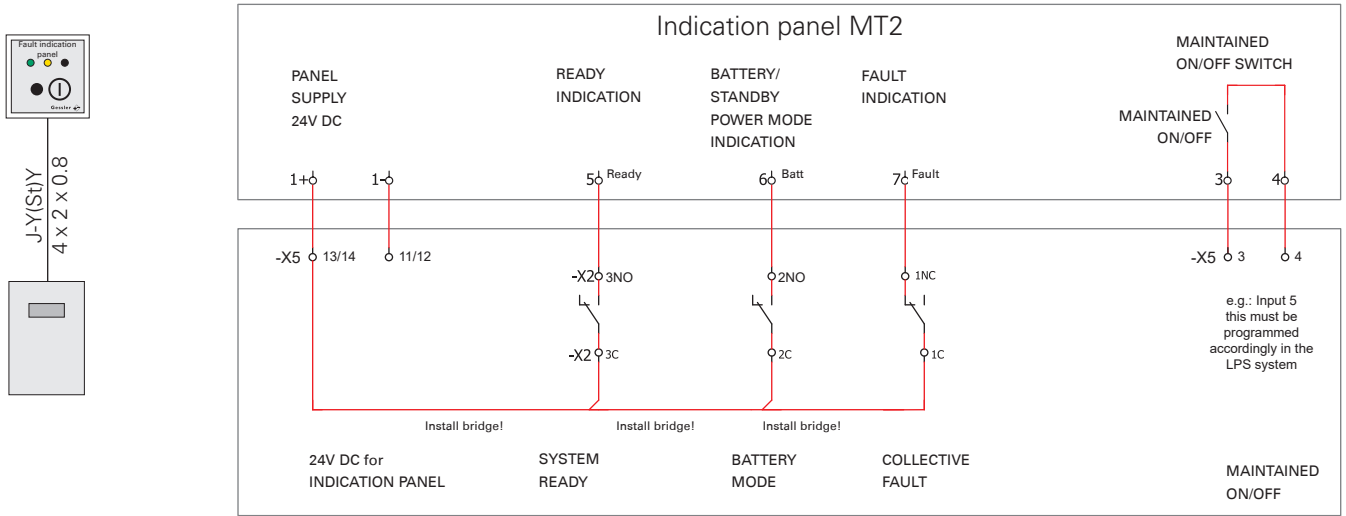

DISPLAY OF SOFTWARE /WEB-MASTER VISUALISATION

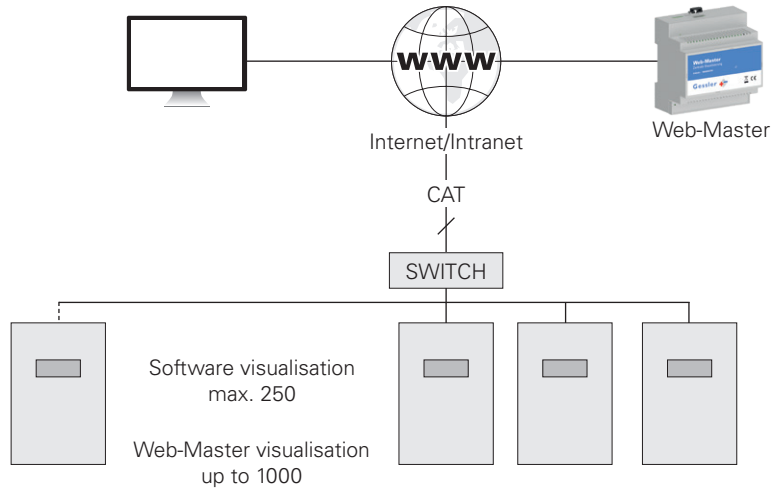

DIMENSIONS

MERLIN QUATTRO LIGHT

EQUIPMENT CABINETS

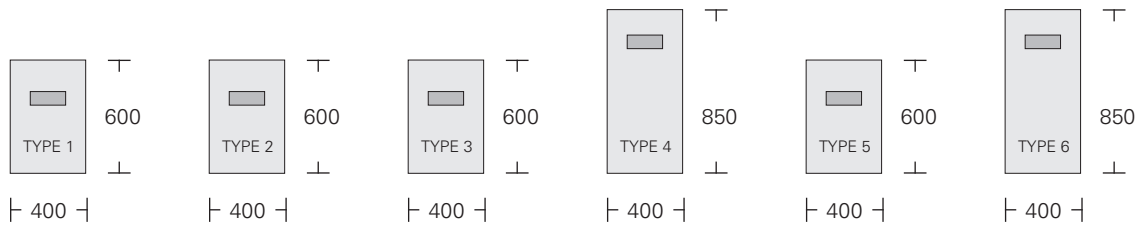

TECHNICAL DATA – QUATTRO LIGHT

Version	Power	Charging unit	Dimensions H x W x D [mm]	Weight [kg]
QUATTRO 1 h				
Type 1	250 VA	2.7 A	600 x 400 x 200	25
Type 2	350 VA	2.7 A	600 x 400 x 200	35
QUATTRO 3 h				
Type 3	225 VA	2.7 A	600 x 400 x 200	35
Type 4	350 VA	5.4 A	850 x 400 x 200	61
QUATTRO 8 h				
Type 5	88 VA	2.7 A	600 x 400 x 200	35
Type 6	188 VA	5.4 A	850 x 400 x 200	61

QUATTRO LIGHT IN MAINTENANCE OF INTEGRITY (E30)

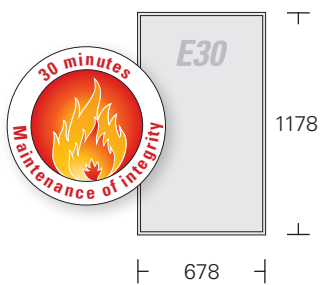

TECHNICAL DATA – E30

Dimensions H x W x D [mm]
1178 x 678 x 345
Weight: 180 kg

ASSEMBLIES | MODULES QUATTRO

The following assemblies and modules are compatible with MERLIN:



MLB10

Address module for MERLIN systems



DMFI

Phase monitor



MLB10DD

Address module with DALI disconnection for MERLIN systems



DMFI-MB

BUS phase monitor for MERLIN systems



MT2

Indication panel



WEB-MASTER

High-level visualisation